

## 04900 ACOPLA CONTRA-BARRA SERIE CLÁSICA SPEED

### INSTRUCCIONES DE MONTAJE

- 1** COMPROBAR QUE TODO EL MATERIAL SE HA SUMINISTRADO CORRECTAMENTE:

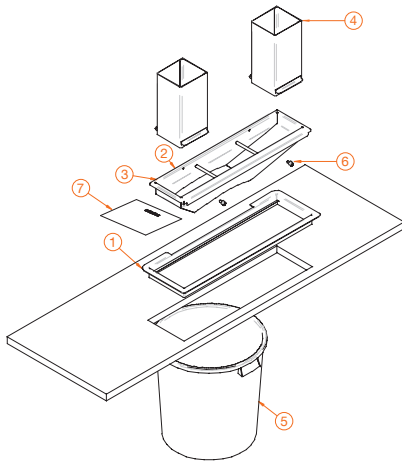

- 2** CALAR BANCO PARA ENCAJE DE PIEZAS SEGÚN CROQUIS:

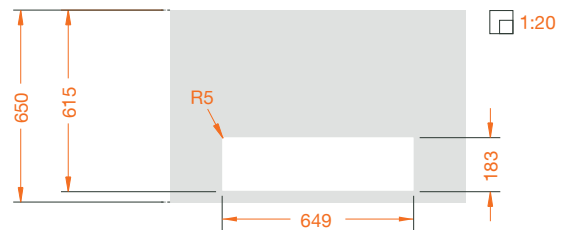

- |   |   |
|---|---|
| 1 | MARCO SOPORTE TOLVA                                 |
| 2 | TOLVA MUEBLE TM                                     |
| 3 | FILTRO MUEBLE                                       |
| 4 | CAÍDA CÔRTEZAS 265 MM.MUEBLE TM (2 UNIDADES)        |
| 5 | CUBO 43 Lis.  |
| 6 | TORNILLOS DIN 84 M-4x6 L. Y TUERCAS DIN 1587 M-4 L. |
| 7 | INSTRUCCIONES KIT CONTRA BARRA SPEED                |

- 3** COLOCAR PIEZAS SEGÚN LA FIGURA ORIGINAL HASTA OBTENER LA SIGUIENTE DISPOSICIÓN:

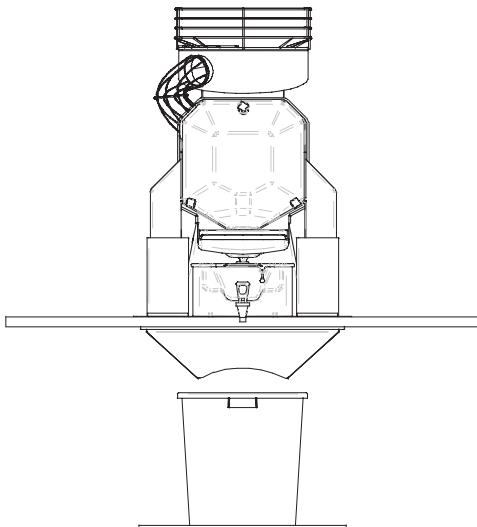

- 4** VISTAS FRONTAL Y LATERAL DEL MONTAJE FINAL

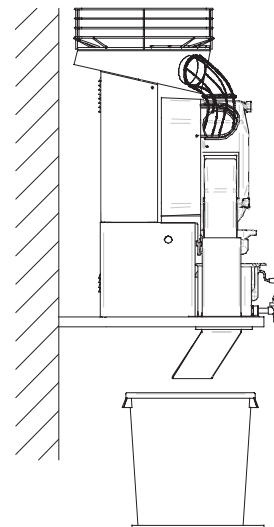

- !** **Importante** Compruebe que ha adquirido el kit adecuado a su modelo de máquina. Verifique que la altura de la caída de las cortezas está ligeramente por debajo del filtro.

04900 COUNTER TOP SERIES CLASSIC **SPEED**  
ASSEMBLY INSTRUCTIONS

**1** CHECK THAT YOU HAVE RECEIVED ALL THE MATERIAL CORRECTLY:

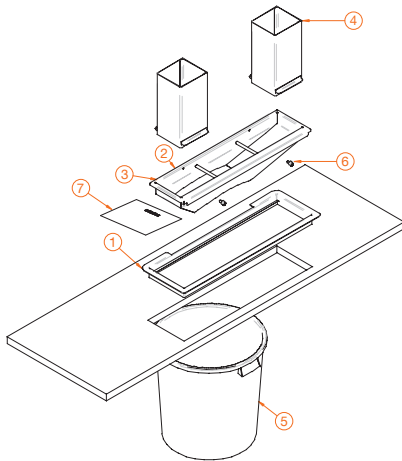

**2** DRILL COUNTER TO FIT PARTS ACCORDING TO DIAGRAM:

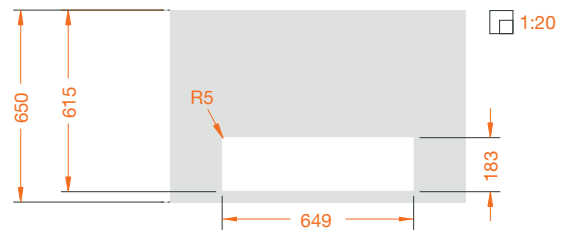

- 1 HOPPER BRACKET FRAME
- 2 PEEL CONE GUIDE STAND TM
- 3 S/S STAND FILTER
- 4 SIDE CHUTES 265 mm. TM (2 UNITS)
- 5 43 Lts. BUCKET
- 6 DIN 84 M – 4X6 I. SCREW AND DIN 1587 M – 4 I. NUT
- 7 COUNTERTOP KIT SPEED INSTRUCTIONS

**3** FIT PARTS ACCORDING TO ORIGINAL FIGURE TO OBTAIN THE FOLLOWING LAYOUT:

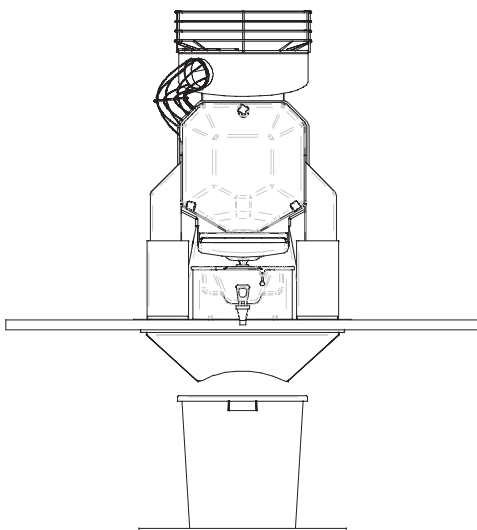

**4** FRONT AND LATERAL VIEW FINISHED ASSEMBLY

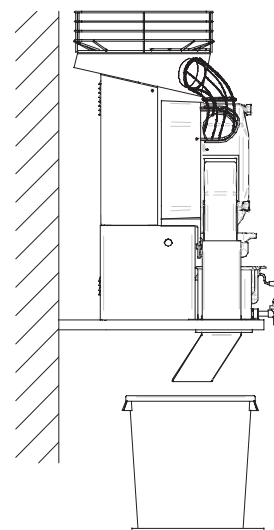

**!** **Important** Check that you have purchased the right kit. Verify that the peel fall height is slightly below the filter.